

ROUND TAPERED COMPOSITE LIGHT POLE DIRECT BURIAL INSTALLATION

SHAKESPEARE O-SERIES DIRECT BURIAL POLES

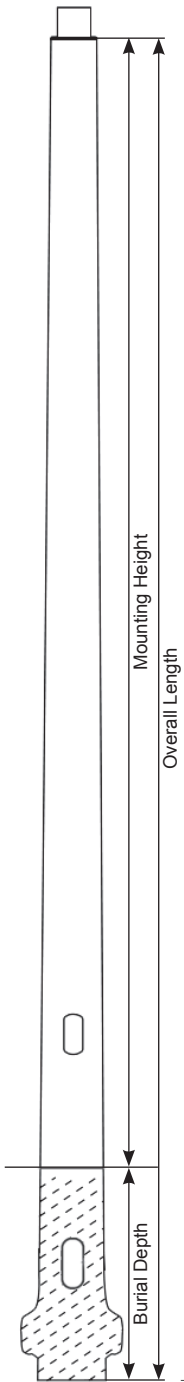

| OVERALL LENGTH | MOUNTING HEIGHT | BURIAL DEPTH | TIP DIAMETER | GROUNDLINE DIAMETER | WEIGHT |
|----------------|-----------------|--------------|--------------|---------------------|--------|
| 13 | 10 | 3 | 4.1 | 5.4 | 26 |
| 14 | 11 | 3 | 4.1 | 5.6 | 29 |
| 15 | 12 | 3 | 4.1 | 5.7 | 31 |
| 16 | 13 | 3 | 4.1 | 5.8 | 34 |
| 18 | 14 | 4 | 4.1 | 5.9 | 37 |
| 19 | 15 | 4 | 4.1 | 6.1 | 38 |
| 20 | 16 | 4 | 4.1 | 6.2 | 42 |
| 21 | 17 | 4 | 4.1 | 6.3 | 45 |
| 22 | 18 | 4 | 4.1 | 6.5 | 49 |
| 23 | 19 | 4 | 4.1 | 6.6 | 51 |
| 24 | 20 | 4 | 4.1 | 6.7 | 52 |

- Mounting heights to 20 feet
- Smooth, semi-smooth or natural finish
- 3 standard and 5 special architectural colors available
- High performance UV and weather-resistant pigmented resin system with an additional pigmented polyurethane coating.
- Tenon top or Drilled and Capped
- Standard 2-1/2" x 5" handhole located 18" above grade
- Standard 2 EA - 2-1/2" x 6" wire access hole 24" below grade
- Anti-rotation flare structurally integrated into the pole base during manufacture
- Poles are individually identified with a permanent embossed tag located 9" from tip.
- Sleeved individually for shipment
- Lightweight, easy to install, saves money

ORDERING INFORMATION

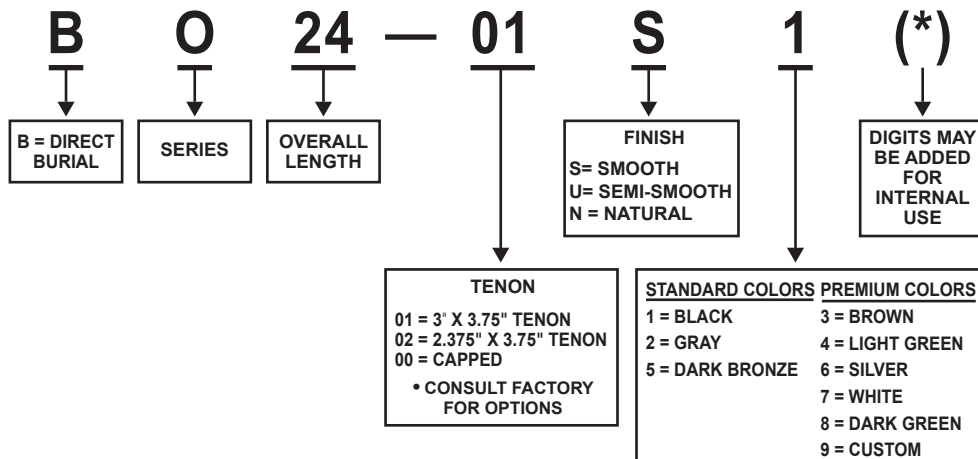

ROUND TAPERED COMPOSITE LIGHT POLE - DIRECT BURIAL INSTALLATION

SPECIFICATIONS

1. Lighting poles shall be fiberglass reinforced composite per Shakespeare design.
2. Wind loading shall be calculated for the appropriate wind velocity with a 3 second gust factor per ASCE.
3. Effective projected area (EPA) is the actual area adjusted with the appropriate drag coefficient (shape factor) to result in an equivalent area having a drag coefficient equal to one (1) using ANSI 136.20

MATERIALS

1. The round tapered pole shall be constructed by the filament winding process from thermosetting polyester resin and contain a minimum of 65 percent "E" type fiberglass by weight. The filament windings shall be continuously applied with uniform tension and shall be placed on the pole helically at low angles to provide axial strength. Additional windings shall be placed on the pole in a circular manner to provide compressive strength.
2. The resin to make the pole shall be ultraviolet resistant and pigmented approximately the same color as the final coating to be applied. A highly weather resistant, pigmented, polyurethane coating shall be applied to the pole. The coating shall have a minimum thickness of 1.5 mils.
3. The poles shall be flame resistant per ASTM D635. Specimens must cease to burn before the gauge mark of 100mm (3.9 inches) is reached.
4. (If applicable) The poles shall be delivered predrilled and capped (if applicable) to accommodate the lighting fixture(s) or mast arm(s) specified.
5. (If applicable) Tenons shall be permanently bonded to the fiberglass shaft and shall be hot-dipped galvanized steel to ASTM A153 or shall be 6061-T6 or A356-T6 aluminum.
6. The handhole opening shall be 2.5" x 5". The handhole cover is attached with a 1/4" socket head screw.

IDENTIFICATION & PACKAGING

Each pole shall bear an identification tag which shall list the model, catalog number, month and year of manufacture.
 Each pole shall be individually packaged for protection during shipping.

TESTING

The surface shall have been tested for a minimum of 5000 hours of accelerated testing in accordance with ASTM G154 (UV-A Lamp 340 NM wavelength 130° F, cycle lamp 4 hours on, 4 hours off) with the following performance results:

- Fiber exposure: None | Crazing: None | Chalking: None | Color: Slight dulling may occur

WIND LOADING DATA

Wind speed (mph) values calculated as per ANSI C136.20 for a 3-second gust factor.

| OVERALL LENGTH | MOUNTING HEIGHT | LUMINAIRE MAX WEIGHT (LBS.) | 90 MPH | 100 MPH | 110 MPH | 120 MPH | 130 MPH | 140 MPH | 150 MPH |
|----------------|-----------------|-----------------------------|--------|---------|---------|---------|---------|---------|---------|
| 13 | 10 | 150 | 11.8 | 9.2 | 7.5 | 6.2 | 5.2 | 4.4 | 3.8 |
| 14 | 11 | 150 | 11.3 | 8.8 | 7.2 | 5.9 | 5.0 | 4.2 | 3.6 |
| 15 | 12 | 150 | 10.2 | 8.0 | 6.5 | 5.3 | 4.4 | 3.7 | 3.2 |
| 16 | 13 | 150 | 9.4 | 7.4 | 5.9 | 4.9 | 4.1 | 3.4 | 2.9 |
| 18 | 14 | 150 | 8.7 | 6.8 | 5.5 | 4.5 | 3.7 | 3.1 | 2.6 |
| 19 | 15 | 100 | 9.2 | 8.0 | 6.5 | 5.3 | 4.4 | 3.7 | 3.1 |
| 20 | 16 | 100 | 9.3 | 7.3 | 5.9 | 4.8 | 4.0 | 3.3 | 2.8 |
| 21 | 17 | 100 | 8.6 | 6.7 | 5.4 | 4.4 | 3.6 | 3.0 | 2.5 |
| 22 | 18 | 100 | 7.9 | 6.1 | 4.9 | 3.9 | 3.2 | 2.7 | 2.2 |
| 23 | 19 | 100 | 7.2 | 5.6 | 4.4 | 3.6 | 2.9 | 2.4 | 2.0 |
| 24 | 20 | 100 | 6.6 | 5.1 | 4.0 | 3.2 | 2.6 | 2.1 | 1.8 |

Direct Embedded Detail

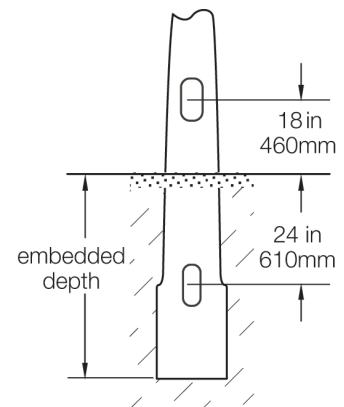

SPC7695 11/15 skp-cs.com carries the most current spec information and supercedes these guidelines.