



Drive Train

Industry-Best Reliability that Keeps Your
Machine Running Year After Year



The Leader in Precision Irrigation.®

Stronger from the Inside Out



#DYK

DID YOU KNOW? The Valley center drive averages 3x the life of competitor products.



The Brand Trusted by Generations of Growers

The drive train is the most important part of your irrigation machine. Without it, nothing else matters, and Valley builds ours to handle the toughest conditions and most difficult terrain.

Valley® Center Drive

The Valley center drive is built stronger, lasts longer and uses less energy than other irrigation drive motors. Standard-speed and high-speed options are available, with the standard-speed motor requiring the least amount of power in the industry.

Key Features:

- Steel gears
- Internally vented junction box
- Integral pinion gear
- Helical gears
- Special motor windings for high-torque applications

Benefits:

- Prevents moisture and contaminants from corroding the wire connections
- Eliminates coupler, improves reliability
- More tooth contact than spur gears, providing more torque capacity and quieter operation
- 40% higher operating torque than the competition

Valley Motor Shield

The Valley motor shield is made of tough, flexible material that protects your center drive from livestock, weather and corrosive water. Your motor will be completely covered while the vents on the bottom and top ensure the motor stays cool and dry. The cover can be easily removed when it's time to service your machine.

Field Tests Show Your ROI

- The Valley center drive averages three times the life of competitive center drives.
- 40% higher torque rating than competition
- Highest efficiency available
- Lowest power consumption available

Center Drive Application Guide

Model	Recommendations
34 RPM	Standard quarter mile machines where chemigation will not be used; lowest power requirement in the industry means energy savings
68 RPM	Long machines or when chemigation will be used; reduces time required to apply chemicals and move the pivot
43 RPM	Replacement for non-Valley machines Not available with VS-7000
136 RPM	Machines using Valley X-Tec® FastPass™ technology

The Strongest, Most Trusted Gearbox You Can Buy



11 Reasons the Valley Gearbox is the Best

- Large capacity rubber diaphragm** — Expands with heat and pressure to minimize water condensation
- Expansion chamber** — Cap made of corrosion resistant cast aluminum; rubber diaphragm allows oil to expand and contract during operation. Vented cap prevents pressure buildup, prevents seal from leaking.
- Input and output bearings** — American made and case hardened to provide the highest quality and load rating available in the industry
- Threaded endcap** — Allows accurate bearing preload to increase bearing life
- Worm gear** — High-strength ductile iron provides significantly longer wear life than steel when combined with a cast iron bull gear
- 52:1 gear ratio** — Full recessed tooth design keeps oil between engaged gears.
- Tooth design** — Industry-exclusive 25° tooth angle provides 40% longer life and better reliability in tough conditions compared to normal 14½° tooth designs
- Bull gear** — High-strength cast iron provides the highest load capacity in the industry and longest life. Optional bronze gear is available for extreme conditions.
- Largest bull gear neck and keyway** — For strength in critical load-bearing area
- Multi-viscosity gearbox oil** — Exceeds 85w140 GL5 oil for long gear wear under extreme load conditions
- Longest output shaft (steel)** — Exclusive to Valley® gearboxes. Provides extra clearance between the gearbox and wheel flange, reducing mud buildup, resulting in reduced seal damage and extended gearbox life. Special offset rims position the tire back close to the gearbox to minimize bearing loads ... another Valley exclusive.

All these factors add up to one thing — the best gearbox in the industry, giving you long, trouble-free equipment life.

Valley® Irrigation's mission is to provide growers the most durable irrigation equipment in the industry. That's why the Valley gearbox is designed and manufactured in the USA. We life-test each Valley gearbox before it leaves our factory and arrives in your field, giving you peace of mind that you have the most reliable gearbox available.

Features:

- 25° tooth angles — Provide greater load capacity and wear resistance than the competition
- Expansion chamber — Cap made of noncorrosive cast aluminum; rubber diaphragm allows oil to expand and contract during operation
- Ductile iron worm gear — Provides higher load capacity against cast iron versus a steel worm gear
- Bull gear — Highest load capacity in the industry and longest life
- Threaded endcap — Allows accurate bearing preload to increase bearing life
- 52:1 gear ratio — Full recessed tooth design keeps oil between engaged gears
- Longest output shaft — This Valley exclusive provides extra clearance between gearbox and tire to reduce mud buildup, which in turn prevents seal damage and extends the gearbox life

The Valley Gearbox vs. Competitors' Gearbox

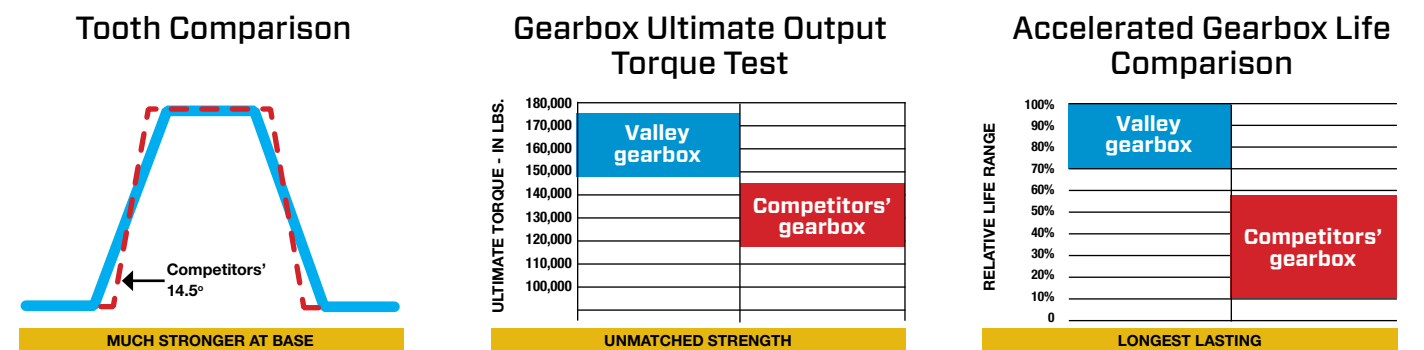



Product Specifications:

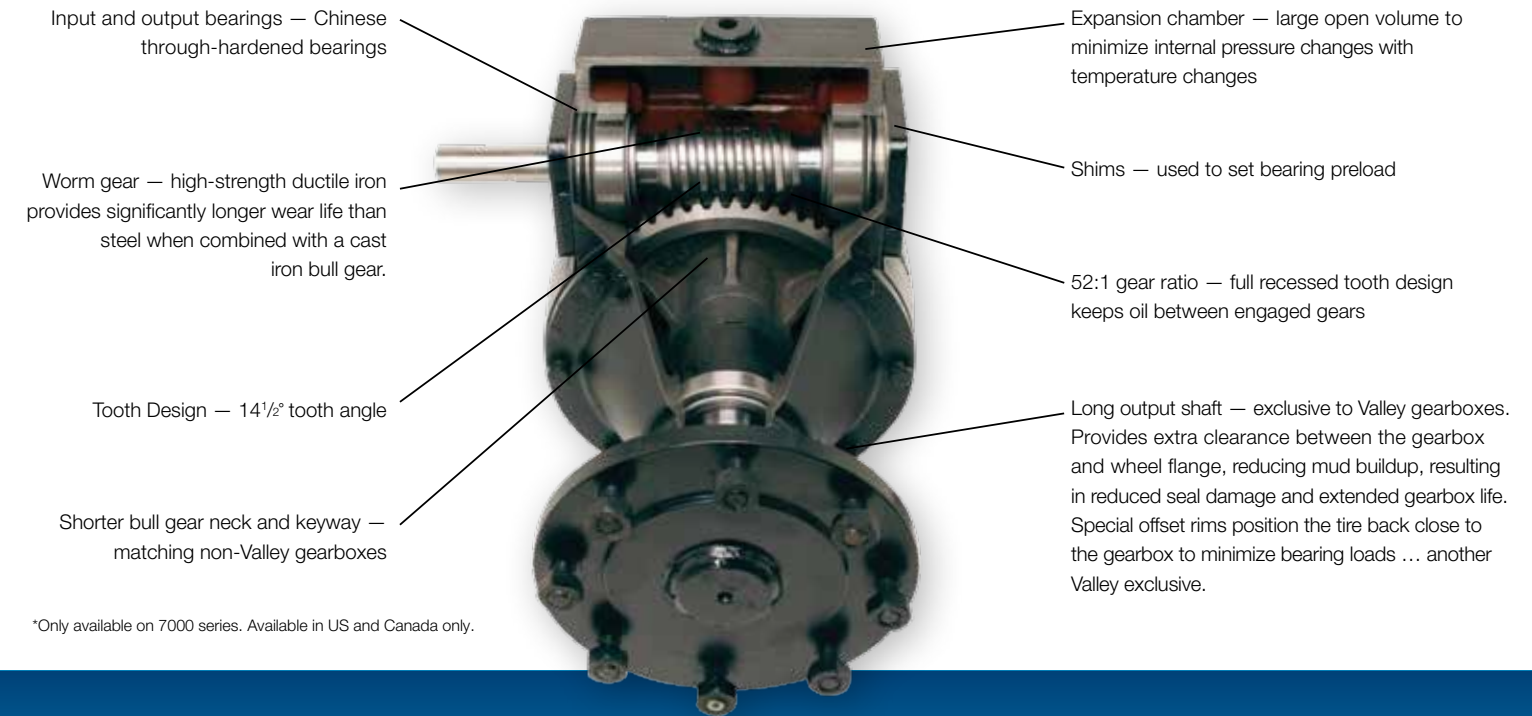

*Only available on 7000 series. Available in US and Canada only.

Gearbox Comparison

VS-7000 Gearbox

The VS-7000 center drive offers the performance you expect from Valley, for less demanding terrain.

Key Features:

- Valley-certified performance specification
- Same helical gearbox
- Same amp draw
- Same torque rating

Not available on the 8000 series. Only available in the US and Canada.



Gearbox Features	Valley Gearbox Benefits	VS-7000 Gearbox Benefits
Superior design	Three times the life of competitive gearboxes, based upon independent tests	Longer life than non-Valley gearboxes
Bull gear	20% higher torque capacity, based on independent tests	Comparable to non-Valley gearboxes
Special offset rims	Positions tire close to gearbox to minimize bearing loads for longer life	Positions tire close to gearbox to minimize bearing loads for longer life
input and output bearings	American made and case hardened; industry's highest load rating for longer life.	Through-hardened that results – comparable to non-Valley gearboxes
Gearbox housing	More material in high-stress areas to handle extreme operating conditions	Comparable to non-Valley gearboxes
Bronze bull gear option	Provides additional load capabilities with hardened steel worm for extreme operating conditions or extended life under less-severe conditions	Not available

Traction & Flotation

Feature	Benefit	Two-Wheel Drive	Three-Wheel Drive	Track Drive	Articulating Four-Wheel Drive	Articulating Track Drive
Wide wheel base	Improved span stability on rolling ground and in windy conditions	✓	✓	✓	✓	✓
Wide range of tire sizes	Traction and flotation options to match field conditions	✓	✓		✓	
Heavy-duty base beam	Strength to support center tires on ridges		✓	✓		
Increased traction	Helps prevent stuck drive units	✓	✓	✓	✓	✓
Heavy-duty steel tracks	Distributes weight over a wider area than tire options, minimizing ground pressure			✓		✓
Increased flotation	Lower ground pressure, minimizes soil compaction and rut depth	✓	✓	✓	✓	✓
Rough ground capability	Maneuver through varying field conditions	✓	✓		✓	✓
Articulating drive base beams	Tracks and tires maintain contact with the ground and follow sudden changes in field terrain				✓	✓
Two center drives	Reduces motor load for longer life				✓	✓
Four-wheel drive tires	All four tires are driven, providing better traction and less downtime				✓	✓
Tracked drive unit with longer wheel base	Increased track length for more flotation					✓
Adaptable to tracks	Can add tracks in the future with minimal effort				✓	
Conversion packages	Can retrofit existing Valley drive units		✓	✓	✓	✓
Drive						
Traction	Prevents Getting Stuck	Good	Better	Best	Best	Best
Flotation	Reduces Wheel Rut	Good	Good	Best	Better	Best
Rough Ground Capabilities		Best	Better	Good	Best	Best
Series Availability		5000* 7000* 8000*	7000* 8000*	8000 Only	8000 Only	8000 Only

*5000 and 7000 series only available in US and Canada



See your local authorized Valley dealer for complete details.

valleyirrigation.com

Valmont® Irrigation has a policy of continuous product improvement and development. As a result, certain changes in standard equipment, options, price, etc. may have occurred after the publication of this brochure. Some photographs and specifications may not be identical to current production. Your local Valley® dealer is your best source for up-to-date information. Valmont Irrigation reserves the right to change product design and specifications at any time without incurring obligations.

©2018 Valmont Industries, Inc., Valley, NE 68064 USA. All rights reserved.