

ROUND TAPERED COMPOSITE LIGHT POLE ANCHOR BASE INSTALLATION

SHAKESPEARE AC-SERIES ANCHOR BASE POLES

| MOUNTING HEIGHT | TIP DIAMETER | GROUNDLINE DIAMETER | WEIGHT |
|-----------------|--------------|---------------------|--------|
| 30 | 6.6 | 10.4 | 228 |
| 31 | 6.6 | 10.6 | 233 |
| 32 | 6.6 | 10.7 | 237 |
| 33 | 6.6 | 10.9 | 241 |
| 34 | 6.6 | 11.0 | 246 |
| 35 | 6.6 | 11.1 | 250 |
| 36 | 6.6 | 11.3 | 264 |
| 37 | 6.6 | 11.4 | 271 |
| 38 | 6.6 | 11.5 | 279 |
| 39 | 6.6 | 11.7 | 286 |
| 40 | 6.6 | 11.8 | 289 |
| 41 | 6.6 | 11.9 | 292 |
| 42 | 6.6 | 11.9 | 293 |
| 43 | 6.6 | 11.9 | 294 |
| 44 | 6.6 | 11.9 | 298 |
| 45 | 6.6 | 11.9 | 321 |

- Mounting heights to 45 feet
- Smooth, semi-smooth or natural finish
- 3 standard and 5 special architectural colors available
- High performance UV and weather-resistant pigmented resin system with an additional pigmented polyurethane coating.
- Tenon top or Drilled and Capped
- Standard 2-1/2" x 5" handhole located 18" above grade
- Poles are individually identified with a permanent embossed tag located 9" from tip.
- Sleeved individually for shipment
- Lightweight, easy to install, saves money

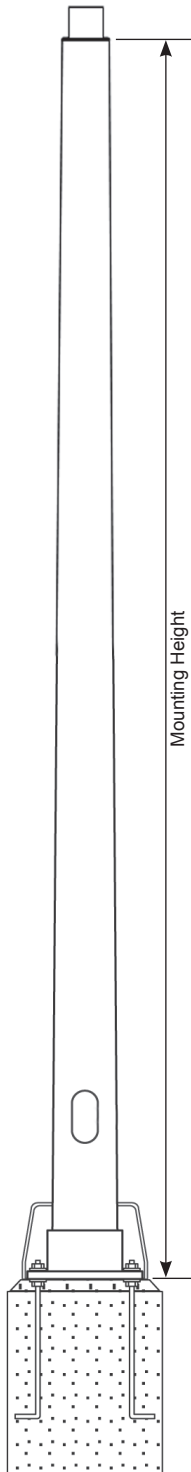

ORDERING INFORMATION

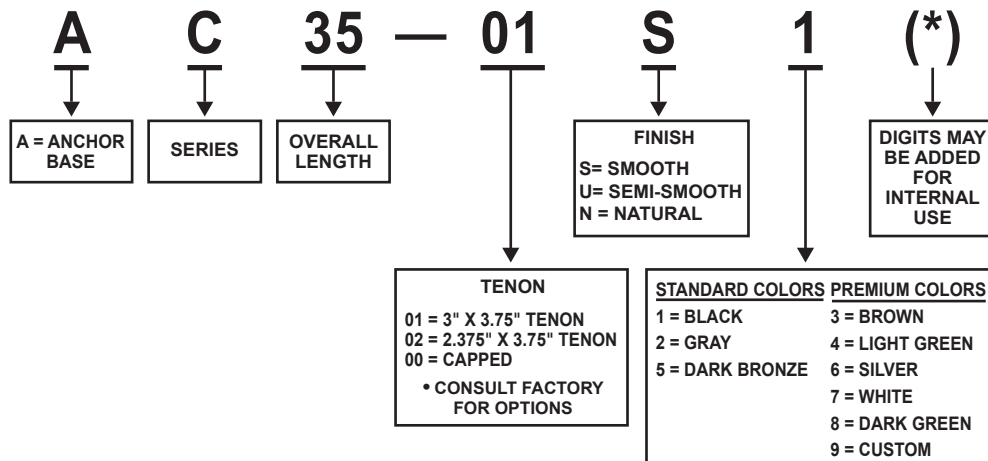

ROUND TAPERED COMPOSITE LIGHT POLE - ANCHOR BASE INSTALLATION

SPECIFICATIONS

POLE SHAFT

The pole shaft shall be round tapered, smooth with a .14"/3.5mm per foot taper. The hand hole shall be 2.5"/62mm x 5"/125mm with a cover. The shaft shall be constructed of continuous fiberglass filament combined with a thermosetting resin. The glass filament shall be helically wound at alternating high and low angle layers for maximum compressive and bending strength. The hand hole area and hardware attachment areas shall be reinforced. The poles shall be designed with a minimum safety factor of 1.5:1 and have a maximum deflection of 15% under full wind loading conditions.

The post shall be non-conductive and chemically inert.

PERFORMANCE CRITERIA

The post shall be designed with a minimum safety factor of 1.5:1 and have no more than a 15% deflection at full wind loading. The post shall deflect no more than 2.5% of the above-ground length with 100 lbs. of lateral top load. Poles shall be tested and rated per ANSI C136.20-2012.

ANCHOR BASE

Anchor bases shall be constructed of primed and painted aluminum or galvanized steel. The base shall be factory bonded to the pole.

TENON

A painted galvanized steel or aluminum tenon shall be firmly bonded to the pole for mounting a post-top luminaire or arm.

FINISH

The surface of the post shall be uniform and consistent for the entire length of the post. A UV-resistant catalyzed urethane coating shall be extremely durable and retains its gloss after a 5000 hour exposure test (ASTM G-154) to the sun, with no dulling or chalking of the surface.

BASE COVER

The standard base cover shall be a round or square two-piece cover. All base covers shall be corrosion free and painted to match pole.

WARRANTY

The products shall be warranted to be free of defects for three years from the date of shipment from the factory.

Anchor Base Installation - AC

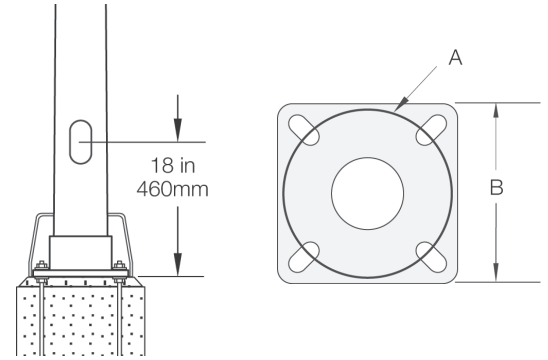

Anchor Base Dimensions for AC-Series

- Hand hole is 2.5"/62mm x 5"/125mm

| SHAFT LENGTH | BOLT CIRCLE (A) | BASE PLATE SIZE (B) | SHROUD NUMBER | ANCHOR BOLTS | SLOT SIZE |
|--------------|-----------------|---------------------|---------------|--------------|-----------|
| 30' | 14.5" | 13.28" | OPSH-2930 | 1.25" | 1.5" x 2" |
| 31'-35' | 15.0" | 13.53" | OPSH-3435 | 1.25" | 1.5" x 2" |
| 36'-45' | 15.5" | 14.00" | OPSH-4047 | 1.25" | 1.5" x 2" |

WIND LOADING DATA

Wind speed (mph) values calculated as per ANSI C136.20 for a 3-second gust factor.

| MOUNTING HEIGHT | LUMINAIRE MAX WEIGHT (LBS.) | 90 MPH | 100 MPH | 110 MPH | 120 MPH | 130 MPH | 140 MPH | 150 MPH |
|-----------------|-----------------------------|--------|---------|---------|---------|---------|---------|---------|
| 30 | 300 | 22.3 | 17.8 | 14.3 | 11.4 | 9.2 | 7.4 | 6.0 |
| 31 | 300 | 22.5 | 17.9 | 14.4 | 11.5 | 9.2 | 7.4 | 5.9 |
| 32 | 300 | 22.0 | 17.5 | 14.0 | 11.2 | 8.9 | 7.1 | 5.7 |
| 33 | 300 | 21.6 | 17.2 | 13.8 | 10.8 | 8.6 | 6.9 | 5.4 |
| 34 | 300 | 21.2 | 16.9 | 13.4 | 10.5 | 8.4 | 6.6 | 5.5 |
| 35 | 300 | 21.1 | 16.8 | 13.2 | 10.4 | 8.2 | 6.5 | 5.1 |
| 36 | 300 | 20.6 | 16.4 | 12.8 | 10.1 | 7.9 | 6.2 | 4.8 |
| 37 | 300 | 20.4 | 16.2 | 12.6 | 9.8 | 7.7 | 6.0 | 4.6 |
| 38 | 300 | 20.5 | 16.2 | 12.6 | 9.8 | 7.6 | 5.9 | 4.5 |
| 39 | 300 | 19.5 | 15.4 | 11.9 | 9.2 | 7.1 | 5.4 | 4.1 |
| 40 | 300 | 19.5 | 15.3 | 11.8 | 9.1 | 7.0 | 5.3 | 3.9 |
| 41 | 300 | 14.0 | 10.9 | 8.1 | 5.9 | 4.1 | 3.0 | 1.9 |
| 42 | 300 | 13.4 | 10.3 | 7.6 | 5.5 | 3.9 | 2.6 | 1.6 |
| 43 | 300 | 12.7 | 9.8 | 7.1 | 5.1 | 3.5 | 2.3 | 1.3 |
| 44 | 300 | 12.1 | 9.3 | 6.7 | 4.7 | 3.2 | 2.0 | 1.0 |
| 45 | 300 | 11.5 | 8.7 | 6.2 | 4.3 | 2.8 | 1.6 | 0.6 |

Wind speed values are for a 3-second gust. Calculated per ANSI C136.20-2012. Assumes load 12 inches above the pole top. Safety factor = 1.5:1. Maximum weight for tenon mount is 300 lbs; for side mounting, total loading cannot exceed 75 lbs (max loading includes all attachments, arms, fixtures & accessories).

Contact factory for AASHTO or specific local codes.